

SKLAD VEZA I BOJA U HRVATSKIM TKANICAMA

Željko KNEZIĆ, Željko PENAVA, Ana KNEZIĆ, Jasenka LULIĆ-ŠTORIĆ

Tkanica,
kanica,
kurđelica...

Od kuda krenuti?







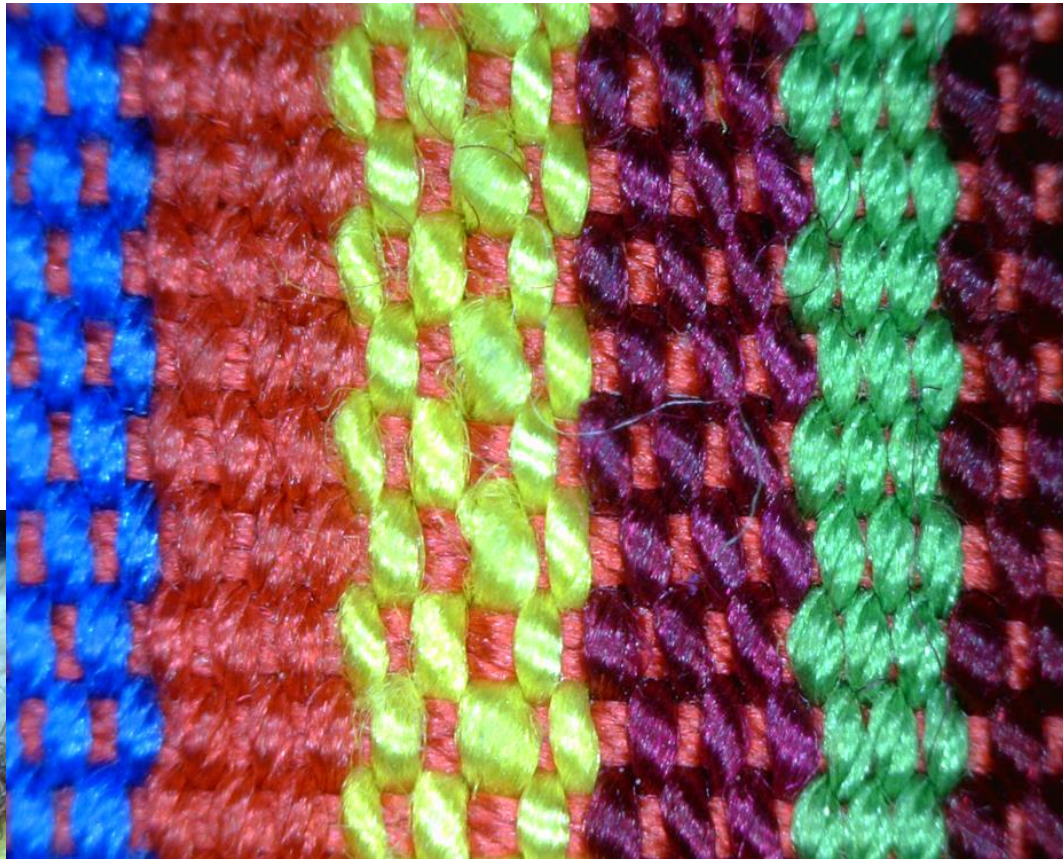



Kanica svil.

100 722
162/90-63
Luka
Morigrad

NMZ-EO 1703

Kanica žen.

Luka

20.7. 1953. 2509 214/53
Kanica Longin, Luka 743

NMZ-EO 744

Kanica žen.

3009 214/53
Filipa Duric
Solun

805

NMZ-EO 756



The image displays a grid-based cross-stitch pattern. At the top, there is a color key with various colored squares (red, green, blue, yellow, white) above a row of small letters: `c c c c z z z z c c b b c c b b c c b b c c c c ž ž ž c p c p c p c p c p c p c p c p c p c p c p c p c p c p c c c c c ž ž ž b b c c b b c c b b c c z z z c c c`. Below this key, there are two primary rows of designs. The first is a decorative border consisting of a repeating sequence of interlocking diamond shapes, each formed by two small black squares. The second is a larger, more complex repeating pattern consisting of several stylized, interconnected shapes that resemble a lattice or a series of interlocking geometric forms. The entire design is presented on a grid background.

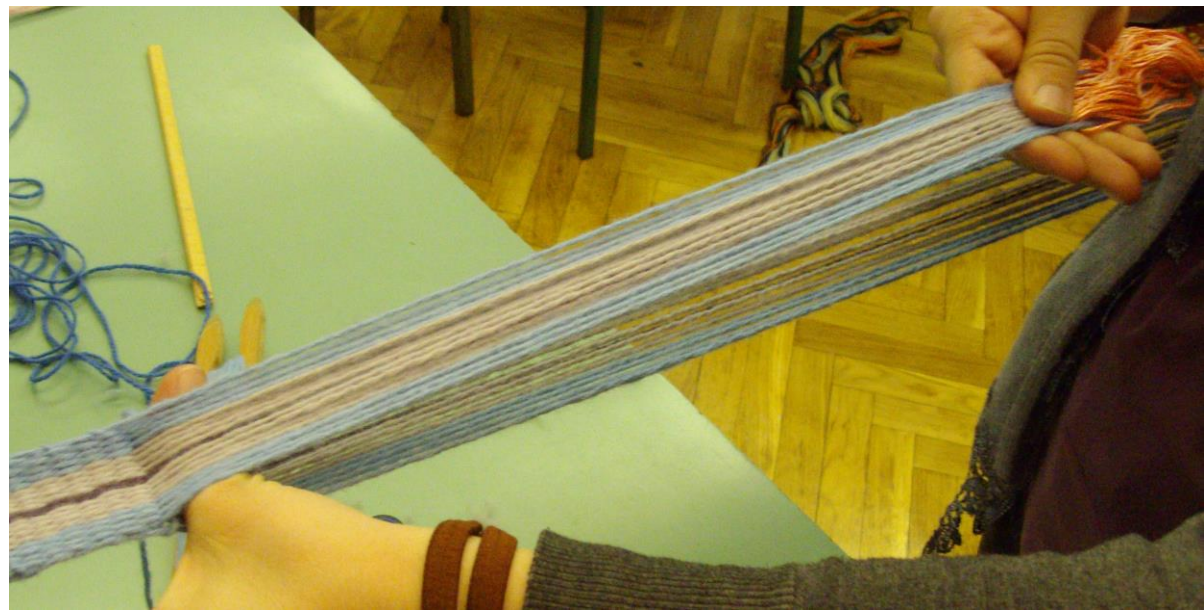
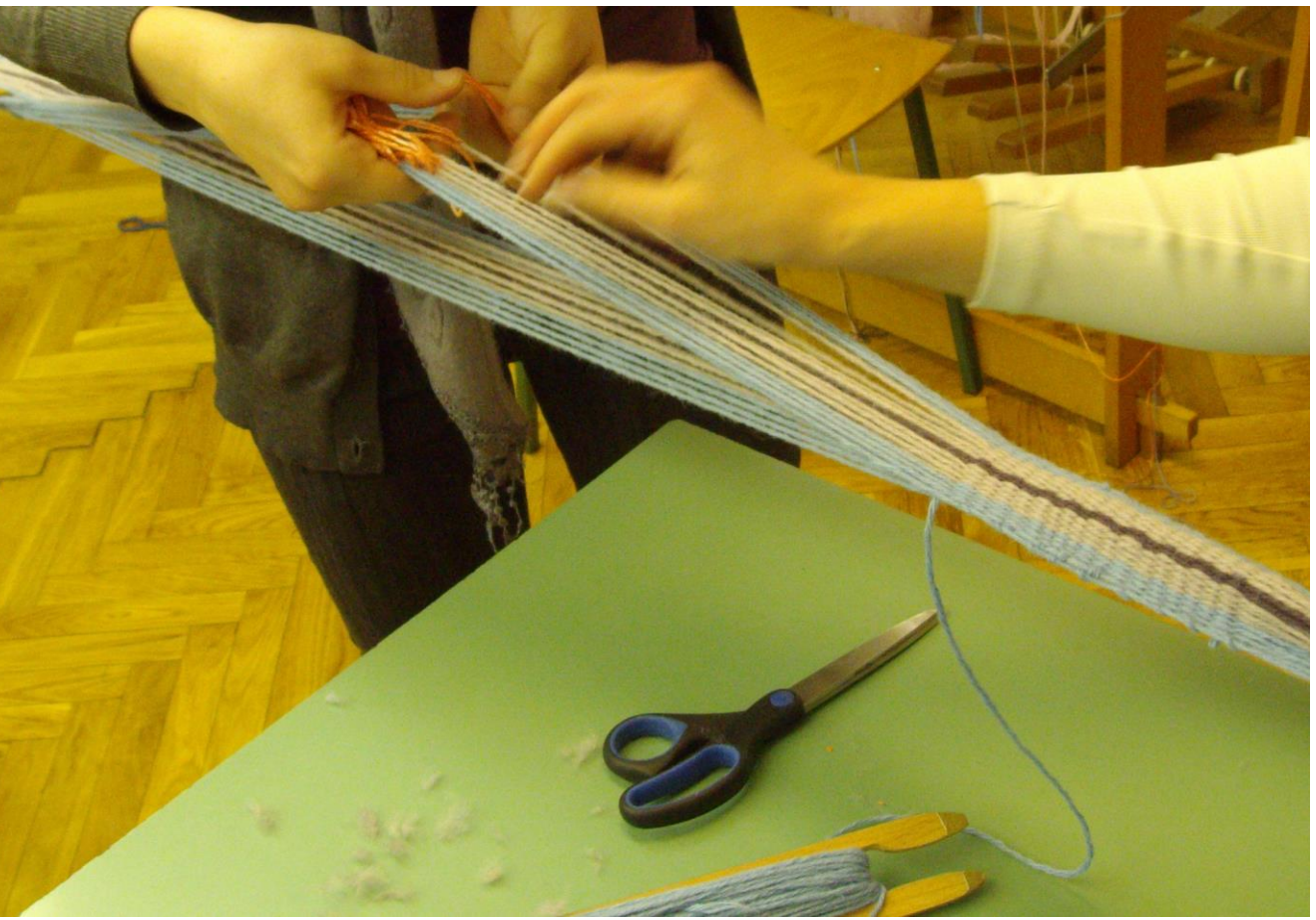

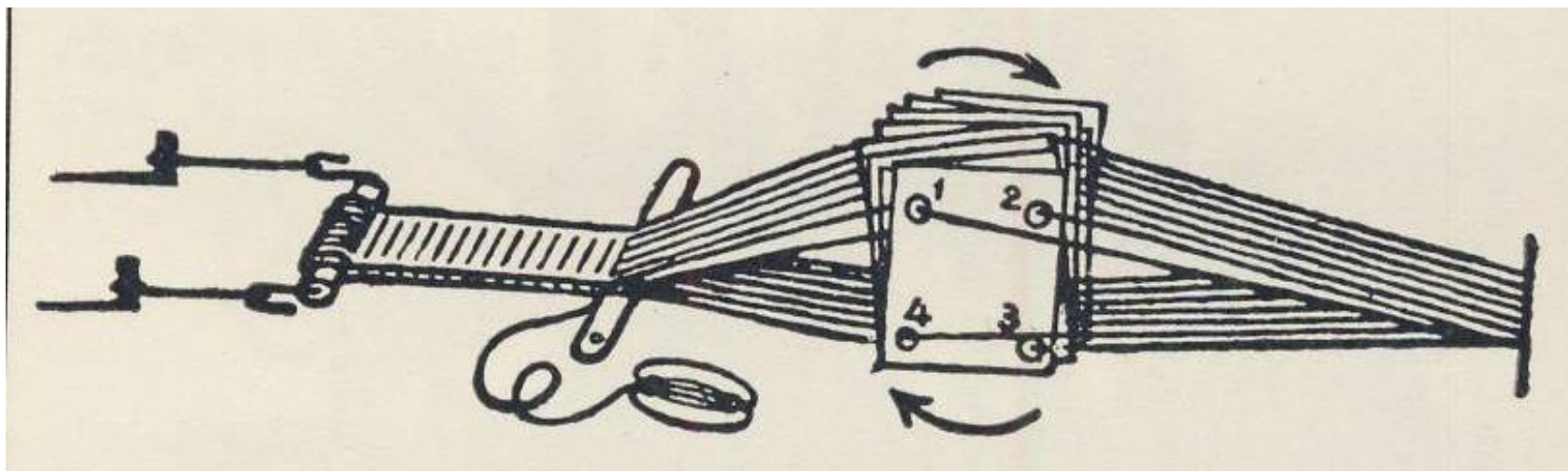
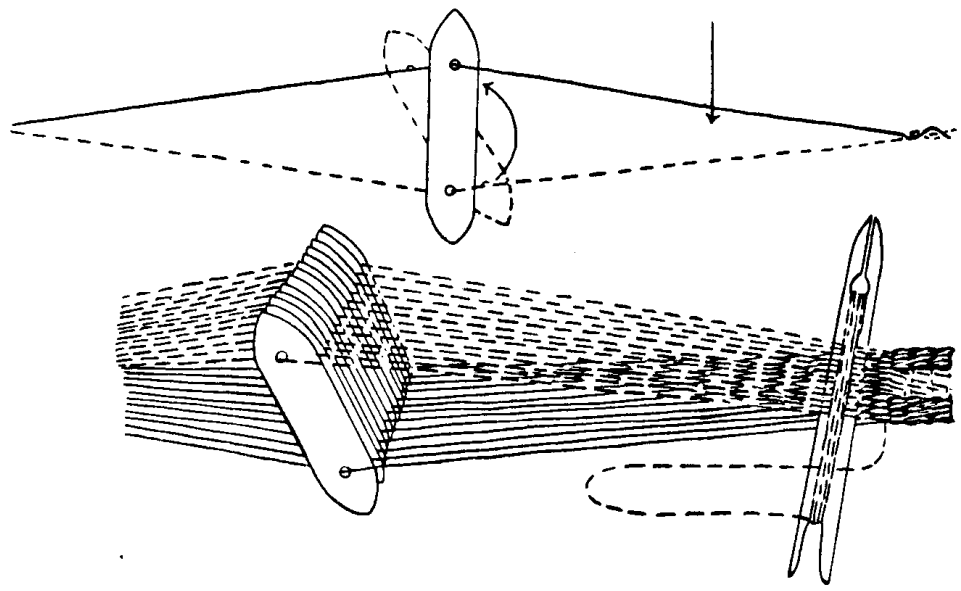

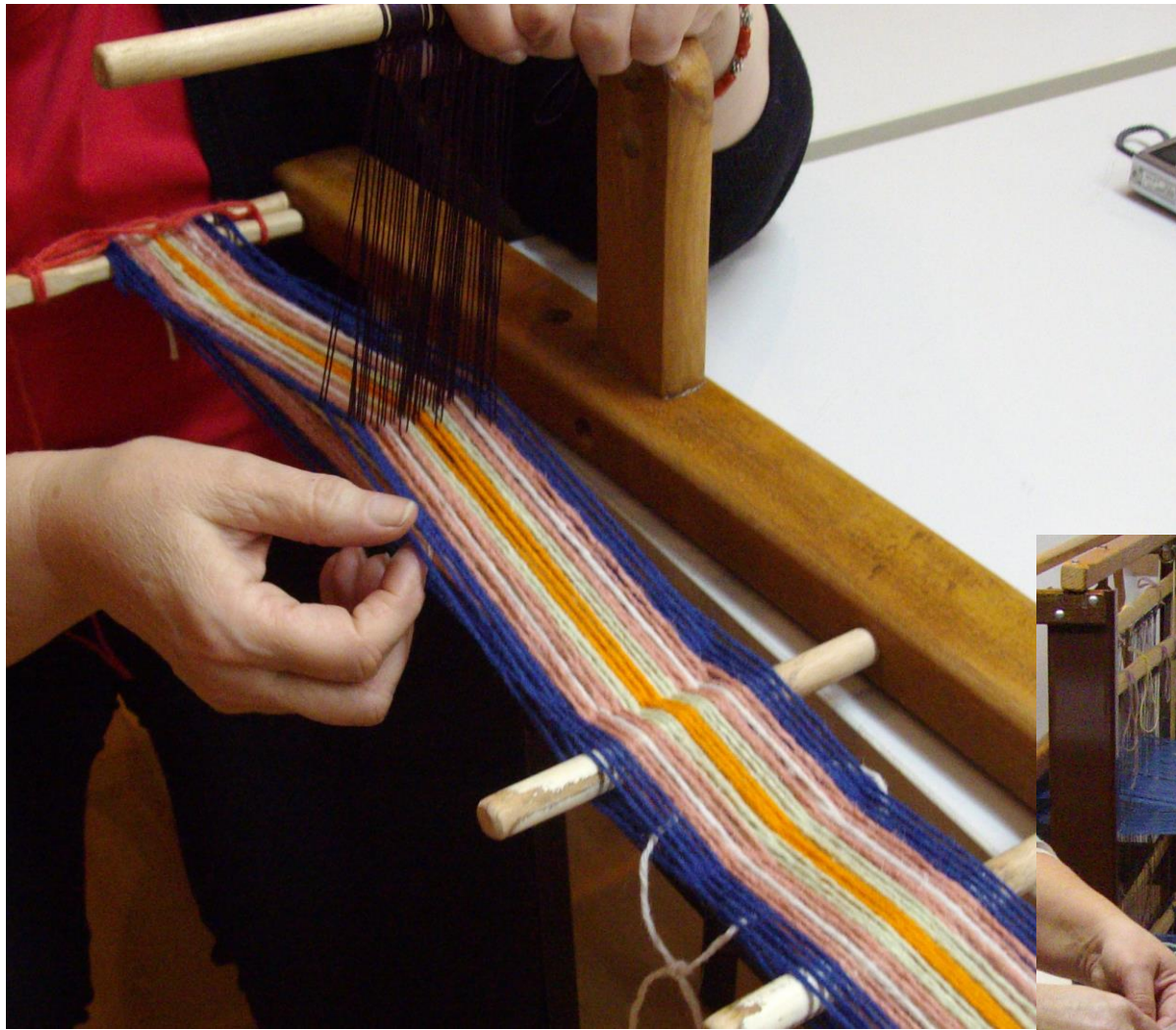





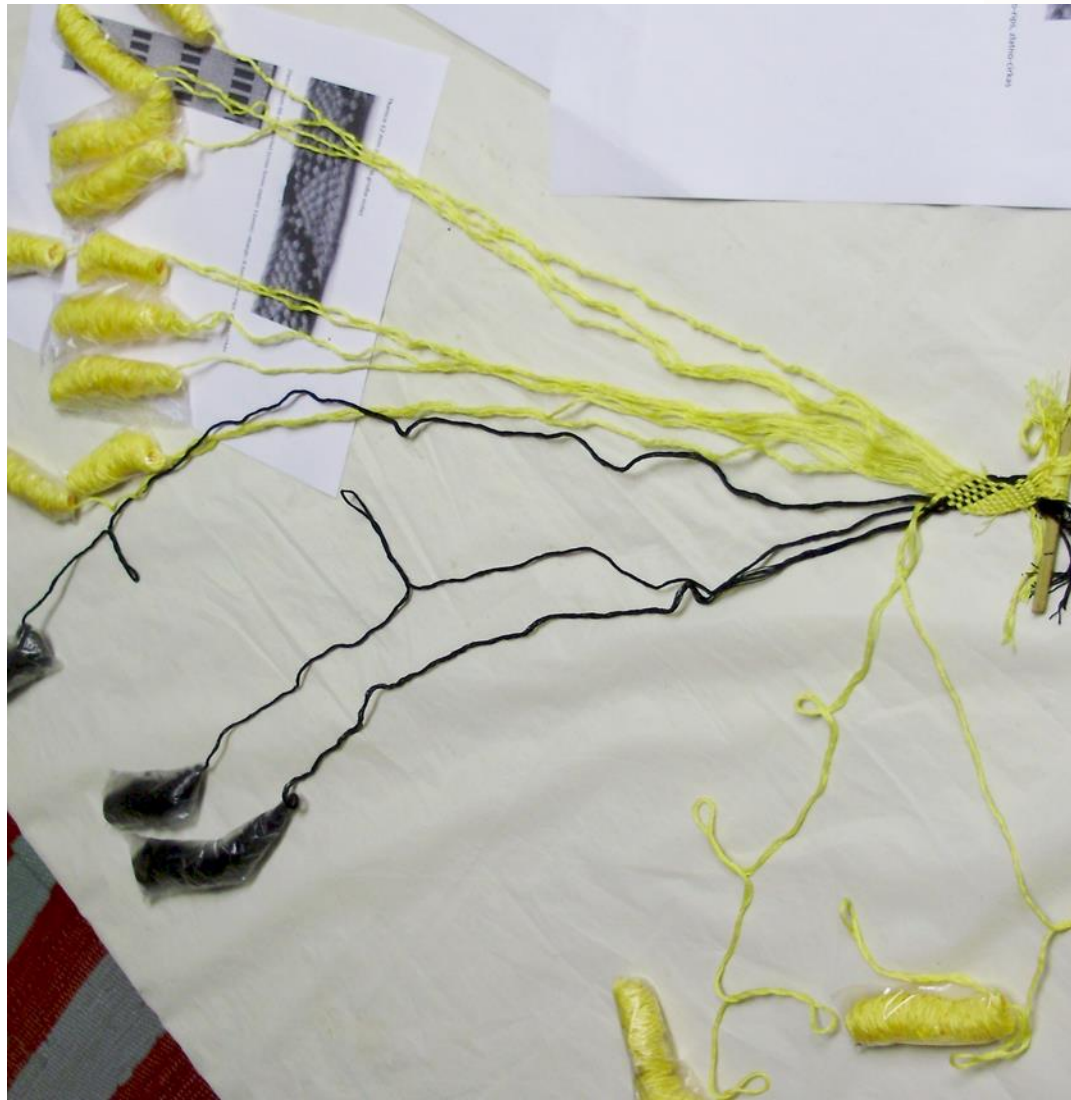

Izvori podataka:

[1]Knezić, Ž.; Kovačević, S.; Penava, Ž.: Ručno tkanje – Nit održanja tradicije u Hrvatskoj // 4. međunarodno znanstveno-stručno savjetovanje Tekstilna znanost i gospodarstvo / Penava, Ž.; Ujević D. (ur.), str. 97-100, ISBN 978-953-7105-39-6, Zagreb, siječanj 2011., Sveučilište u Zagrebu, Tekstilno-tehnološki fakultet, 2011.

[2]Knezić, Ž.: Ručno tkanje – umijeće koje nestaje, stručni časopis Nit, Vol. 1 (1994) 1, 15–17

[3]Knezić, Ž.: Ručni radovi, duh tradicije sunjskog podneblja, Zrin, časopis za povijesna, kulturna i gospodarska pitanja Hrvatskog Pounja, 7 (1994) 1, 47-48

[4]Kovačević, S.: Ručno tkanje, stručna knjiga, Centar za kreativne alternative & Prometej Zagreb, ISBN: 953-6460-37-8, Zagreb, (2003),

[5]Knezić, Ž.; Kovačević, S.; Saraf A.: Prilog očuvanju tradicije ručnog tkanja u dijelu Sisačko-moslavačke županije // 5. međunarodno znanstveno-stručno savjetovanje tekstilna znanost i gospodarstvo / Penava Željko (ur.), str. 95-98, ISSN 1847-2877 Zagreb, Hrvatska, 26. siječnja 2012., Sveučilište u Zagrebu, Tekstilno-tehnološki fakultet, 2012.

[6]Knezić, Ž.: Zapisi usmene predaje, razgovora s Agatom Marić, Jelicom Knezić i Slavicom Knezić iz Graduse Posavske, te Katicom Kuzmanović iz Grede Sunjske. Zabilježeno krajem XX stoljeća

[7]Jurić, M.: Uzgoj lana, Nakladni zavod Hrvatske redakcija ministarstva industrije i rudarstva NRH odjel za stručno školstvo, Zagreb, 1947.

[8]Knezić, Ž.; Kovačević, S.; Knezić, A.: Revitalizacija tradicijskog ručnog tkanja u Republici Hrvatskoj, Tekstil, 61 2012. 7-12, 352-355, ISSN 0492-5882

[9] Narodni muzej Zadar

[10] Zavičajni muzej Čilipi

[11] Gradski muzej Karlovac

[12] Zapisi usmene predaje, razgovora sa članicama udruga: „Baština” Čilipi, „Luzor” Preko, „Sunjanka” Sunja, „KUD Seljačka sloga Sunjska Greda”, „Hrvatska žena Sisak”, „Perlice” Vodice, „Hajdina” Donji Kučan,

[13] Textil-lexikon, Professor-dipl.-ing. Hugo Glafey, Deutsche Verlags.-Anstalt Stuttgart und Berlin 1937

[14] Gavazzi M.: Praslavenski tkalački stan i tkalačka dašćica, Nadbiskupska tiskara u Zagrebu, Zagreb 1926.

HVALA NA POZORNOSTI..